

# PUNCHEON WITHOUT DECKING

NOT TO SCALE

Logs with tops flattened or sawn timber.

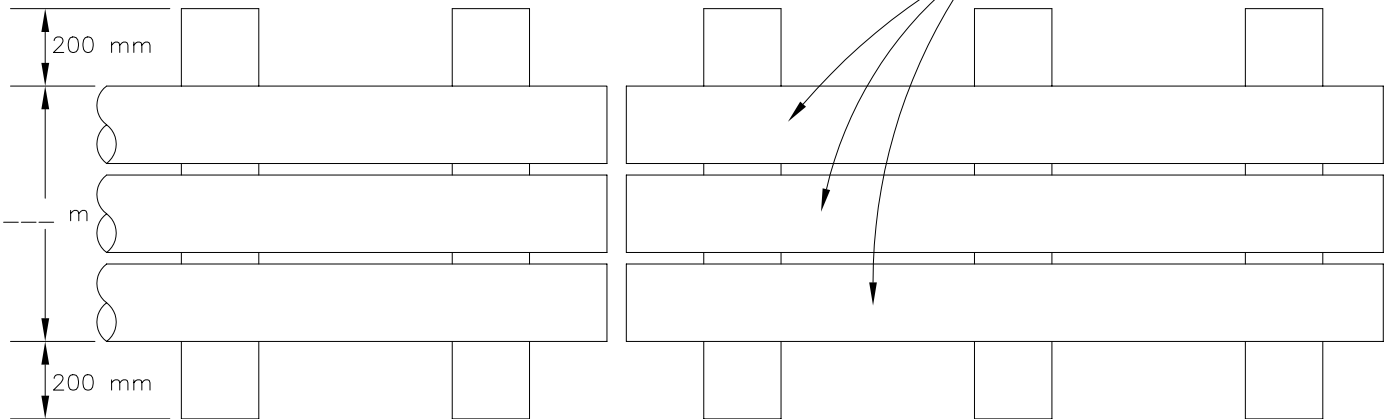

PLAN VIEW

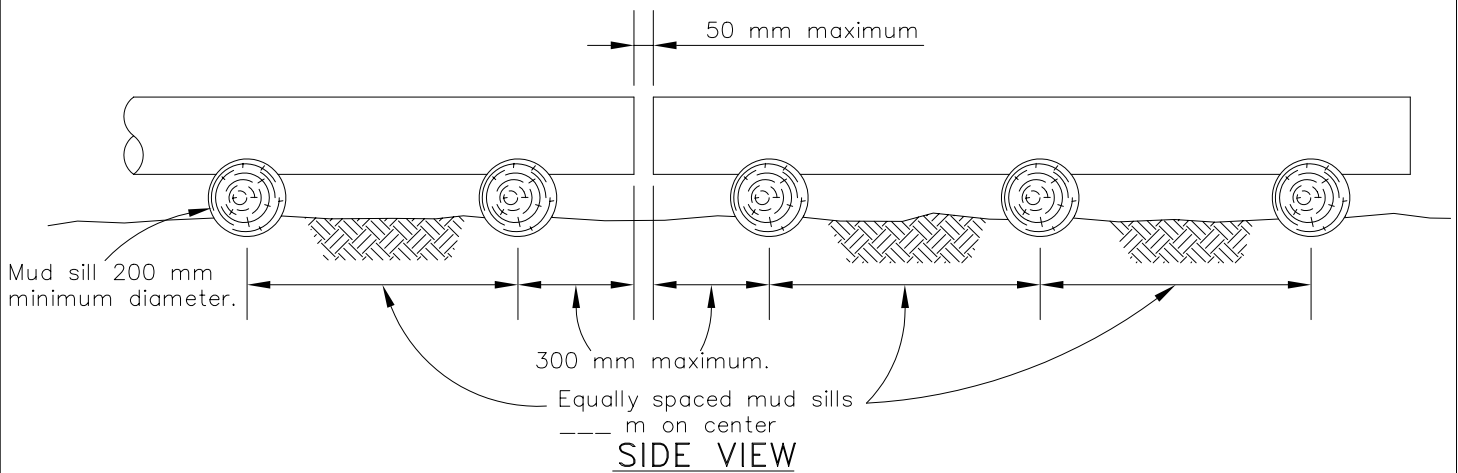

SIDE VIEW

Place round log stringers as close together as possible with no gaps greater than 50 mm.

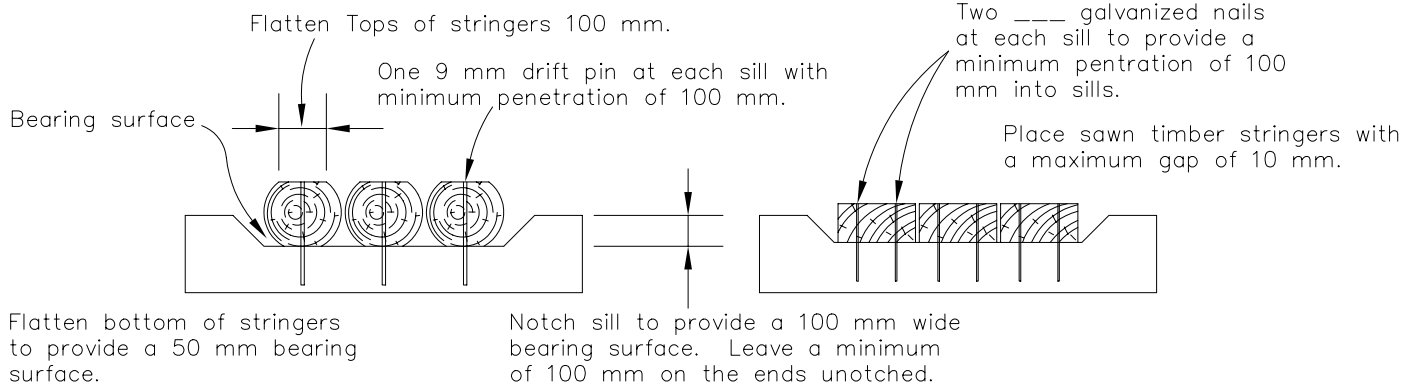

END VIEW  
LOG STRINGER

END VIEW  
SAWN TIMBER STRINGER

MEMBER	TYPE	SPECIES	SIZE (mm)	TREATMENT TYPE	MINIMUM RETENTION (kg/m <sup>3</sup> )
Stringer					
Deck					
Bulkhead					